

Research Report

96-16

**A General Approach to Sizing and Power Density
Equations for Comparison of Electrical Machines**

S. Huang, J. Luo, F. Leonardi, T.A. Lipo

Wisconsin Power Electronics Research Center
University of Wisconsin-Madison
Madison WI 53706-1691

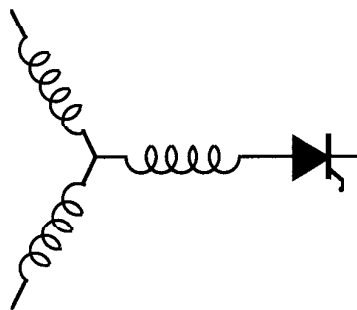

Wisconsin
Electric
Machines &
Power
Electronics
Consortium

University of Wisconsin-Madison
College of Engineering
Wisconsin Power Electronics Research Center
2559D Engineering Hall
1415 Engineering Drive
Madison WI 53706-1691

© June 1996 - Confidential

A General Approach to Sizing and Power Density Equations for Comparison of Electrical Machines

Surong Huang Jian Luo Franco Leonardi Thomas A. Lipo
Fellow, IEEE

Department of Electrical and Computer Engineering
University of Wisconsin-Madison
1415 Engineering Drive
Madison, WI 53706-1691, U.S.A.

Abstract—Based on the concept of the converter fed machines (CFMs), an optimal machine design can be considered as the best match of the machine topology, the power electronic converter and the performance specification. To compare power production potential of machines with various topologies with different waveforms of back emf and current, a general purpose sizing equation and power density equation are needed to compare the main dimensions and power of such machines. In this paper, a general approach is presented to develop and to discuss these equations. Sample applications of the sizing and power density equations are utilized to compare the induction machine and the double-salient permanent magnet (DSPM) machine.

I. INTRODUCTION

In general, comparison of different machine types is a very formidable task since many variables exist for each machine and it is difficult to select those variable which should be held constant for purposes of comparison. One traditional method of comparison is to use the $D_g^2 L_e$ sizing equation, which compares the machine power on the basis of air gap surface diameter D_g and effective stack length L_e .

For many years, researchers have been interested in considering instead the machine outer surface diameter D_o because it is more directly related with the volume and thus the cost and size of the machine. In 1986 V.B. Honsinger developed a $D_o^3 L_e$ sizing equation for induction machines [1] which served to fix the outer surface diameter and stack length. This method paid attention to the optimal electrical loading A and the machine internal geometry for a given power level. Unfortunately, the approach can be shown give reasonable designs only for small pole number since optimizing $D_o^3 L_e$ is clearly not the same as optimizing $D_g^2 L_e$.

The traditional sizing equation is based on the premise that the excitation of the machine is provided by a sinusoidal voltage source resulting in ac machines which produce a sinusoidal emf. It was recognized in [2] and [3] that the emergence of power electronic converters has removed the need for such a concept as the basis for machine design. Beginning with the reluctance and permanent magnet machine, a new phase of electrical machine technology has

been evolving based on the principle that the best machine design is the one that simply produce the optimum match between the machine and the power electronic converter.

With the evolution of converter fed machines (CFMs), it becomes important to compare power potential of machines with vastly different topologies, having a variety of different waveforms of back emf and current. A systematic and easy-to-use method based on sizing equations and the power density concept is needed for comparing the capability of machines with different structure.

In order to eliminate the deficiencies of traditional sizing equation, this paper introduces special factors to account for the effect of non-sinusoidal current and back emf waveforms. A particular effort is made to express the sizing equation which characterizes the output power P_R as a function of overall volume of the machine. Thus, machines can be compared based upon the total occupied volume, instead of the air gap volume. The application of this general purpose sizing equation should provide machine designers with an important tool in their quest for new high power density machines and structures.

II. SIZING EQUATIONS AND POWER DENSITIES

In general, if stator leakage inductance and resistance are neglected, the output power for any electrical machine can be expressed as

$$\begin{aligned} P_R &= \eta \frac{m}{T} \int_0^T e(t) i(t) dt \\ &= \eta m K_p E_{pk} I_{pk} \end{aligned} \quad (1)$$

where emf $e(t)$ and E_{pk} are the phase air gap emf and its peak value. The currents $i(t)$ and I_{pk} are the phase current and the peak phase current, η is the machine efficiency, m is the number of phases of the machine, and T is the period of one cycle of the emf. The quantity K_p is termed the electrical power waveform factor, is defined as

$$K_p = \frac{1}{T} \int_0^T \frac{e(t) \times i(t)}{E_{pk} \times I_{pk}} dt$$

$$= \frac{1}{T} \int_0^T f_e(t) f_i(t) dt \quad (2)$$

where $f_e(t)=e(t)/E_{pk}$ and $f_i(t)=i(t)/I_{pk}$ are the expressions for normalized emf and current waveforms.

The emf in Eq. (1) is given by

$$e(t) = \frac{d\lambda_g(t)}{dt} = K_e N_t B_g \frac{f}{p} D_g L_e f_e(t) \quad (3)$$

where λ_g is the air gap flux linkage per phase, N_t is the number of turns per phase, f is the converter frequency, p is machine pole pairs. The constant K_e is the emf factor which incorporates the winding distribution factor K_w and the per unit portion of the total air gap area spanned by the salient poles of the machine (if any).

From Eq. (3) it is apparent that

$$E_{pk} = K_e N_t B_g \frac{f}{p} D_g L_e \quad (4)$$

In order to indicate the effect of the current waveform, the definition of a current waveform factor K_i is also useful,

$$K_i = \frac{I_{pk}}{I_{rms}} = \left(\frac{1}{T} \int_0^T \left(\frac{i(t)}{I_{pk}} \right)^2 dt \right)^{1/2} \quad (5)$$

where I_{rms} is the rms phase current which is related to the stator electrical loading A_s , wherein

$$A_s = 2m_1 N_t \frac{I_{rms}}{\pi D_g} \quad (6)$$

where m_1 is the number of phases of each stator (if there is more than one stator, each stator has the same m_1).

In the general case, the total electrical loading A should include both the stator electrical loading A_s and rotor electrical loading A_r . So that,

$$A_s = A - A_r = \frac{A}{1 + K_\phi} \quad (7)$$

where $K_\phi = A_r/A_s$ is the ratio of electrical loading on rotor and stator. In a machine topology without a rotor winding, $K_\phi = 0$.

Inserting Eqs. (6) and (7) into (5)

$$I_{pk} = \frac{1}{1 + K_\phi} K_i A \pi \frac{D_g}{2m_1 N_t} \quad (8)$$

Combining Eqs. (1), (4), (8), the following $D_g^2 L_e$ sizing equation is obtained

$$P_R = \frac{1}{1 + K_\phi} \frac{m}{m_1} \frac{\pi}{2} K_e K_i K_p \eta B_g A \frac{f}{p} D_g^2 L_e \quad (9)$$

In most radial air gap flux machines, the aspect ratio coefficient

$$K_L = \frac{L_e}{D_g} \quad (10)$$

should be chosen based upon practical requirements of the application. Alternatively, in [4] and [5], an optimized range of the ratio of stack length vs. pole pitch, was given for conventional motors as a function of peak torque and temperature raise. From this data, through power regression, it is possible to obtain

$$K_L = \frac{\pi}{2} p^{\frac{2}{3}} \quad (11)$$

However, this is clearly not the case for axial air gap flux machines, for which K_L must be carefully derived [6].

Inserting Eq. (10) into (9), it is possible to obtain a D_g^3 sizing equation

$$P_R = \frac{1}{1 + K_\phi} \frac{m}{m_1} \frac{\pi}{2} K_e K_i K_p K_L \eta B_g A \frac{f}{p} D_g^3 \quad (12)$$

To realize the required $D_o^2 L_e$ sizing equation, it is useful to define the ratio [1]

$$\lambda_o = \frac{D_g}{D_o} = f(d_{ss}, d_{cs}, L_{pm}, D_g, p) \quad (13)$$

where d_{ss} is the depth of the stator slot, d_{cs} is the depth of the stator core and L_{pm} is the length of the permanent magnet in the radial direction in the stator if any. In general, a procedure needs to be developed to determine λ_o when studying a specific machine or structure which incorporates the effects of temperature rise, losses, and efficiency requirements on the design. In practice, the depths d_{ss} , and d_{cs} depend upon the stator electrical loading A_s , the current density J_s , the slot fill factor K_{cu} and the flux density in the iron core, the length L_{pm} depends on the air gap flux density and air gap length, the air gap surface diameter D_g is determined by Eq. (12).

The final general purpose sizing equation ultimately takes on the form

$$P_R = \frac{1}{1 + K_\phi} \frac{m}{m_1} \frac{\pi}{2} K_e K_i K_p \eta B_g A \frac{f}{p} \lambda_o^2 D_o^2 L_e \quad (14)$$

For convenience of design and for purposes of comparison the corresponding D_o^3 sizing equation is found to be

$$P_R = \frac{1}{1+K_\phi} \frac{m}{m_1} \frac{\pi}{2} K_e K_i K_p K_l \eta B_g A \frac{f}{p} \lambda_o^3 D_o^3 \quad (15)$$

Finally, the machine power density for the total volume can be defined as

$$\xi = \frac{P_R}{\frac{\pi}{4} D_o^2 L_t} \quad (16)$$

where L_t is the total length of the machine including the stack length and the protrusion of the end winding from the iron stack in the axial direction.

By examining the back emf and current waveform for a particular machine type, the factors, K_i and K_p in the sizing equation can be determined. Several typical waveforms and their corresponding K_i and K_p are shown in Table I.

III. APPLICATION OF THE GENERALIZED SIZING EQUATION TO INDUCTION MACHINES

Considering the first sinusoidal back emf and current waveforms inherent in induction machines (Table I, row 1), it is clear that $K_i K_p = (\sqrt{2}/2) \cos \phi_r$. For an induction machine the factor $K_e = 2\pi K_w$. Then, from Eq. (14), the sizing equation of an induction machine is

$$P_{R(IM)} = \frac{\sqrt{2}\pi^2}{2(1+K_\phi)} K_w \eta \cos \phi_r B_g A \frac{f}{p} \lambda_o^2 D_o^2 L_e \quad (17)$$

The corresponding power density of the induction machine is

$$\xi_{(IM)} = \frac{2\sqrt{2}\pi^2}{(1+K_\phi)} K_w \eta \cos \phi_r B_g A \frac{f}{p} \lambda_o^2 \frac{L_e}{L_t} \quad (18)$$

where $\cos \phi_r$ is the power factor which is related to the rated power $P_{R(IM)}$, the pole pairs p of the machine and the converter frequency f . An estimate of $\cos \phi_r$ for the squirrel-cage motor is

$$\cos \phi_r = 1.07 P_R^{0.015} p^{-0.08} f^{-0.07} \quad (19)$$

The above equation was verified through the NEMA-B squirrel-cage motor data, which were discussed in [5].

In an induction machine K_ϕ is related to the rated power factor $\cos \phi_r$. In [7], a table (Table II below) was given to express the relationship between K_ϕ and $\cos \phi_r$.

TABLE I
TYPICAL PROTOTYPE WAVEFORMS

Model	e(t)	i(t)	K_i	K_p
Sinusoidal waveform			$\sqrt{2}$	$\frac{1}{2} \cos \phi$
Sinusoidal waveform			$\sqrt{2}$	0.5
Rectangular waveform			1	1
Trapezoidal waveform			1.134	0.777
Triangular waveform			$\sqrt{3}$	0.333
Rectangular & Trapezoidal waveform			1.134	0.8
Rectangular & Trapezoidal waveform			1.389	0.556
Trapezoidal waveform			1.389	0.519
Rectangular & Trapezoidal waveform			1.5	0.333
Rectangular waveform			1.225	0.667

TABLE II
VARIATION OF K_ϕ WITH RATED POWER FACTOR $\cos \phi_r$

$\cos \phi_r$	0.65	0.7	0.75	0.8	0.85	0.9	0.95
K_ϕ	0.74	0.77	0.82	0.86	0.9	0.95	0.985

Through power regression, an estimated equation for K_ϕ can be established as

$$K_\phi = 1.06 P_R^{0.0116} p^{-0.062} f^{-0.054} \quad (20)$$

Choice of a proper air gap flux density B_g and stator tooth flux density B_{ts} is another important issue. Ref. [5] offers a discussion on the relationship between B_{ts} and converter frequency f . From this source the stator tooth flux density B_{ts} can be estimated reasonably by

$$B_{ts} = 5.47 f^{-0.32} \quad (21)$$

In addition, Levi [8] has derived an optimal value for B_g expressed as

$$B_g = 0.5 K_{fe} B_{1s} \quad (22)$$

where K_{fe} is the stator lamination factor accounting for the air space between laminations.

Table III shows some typical flux densities suggested for several converter frequencies.

TABLE III
RECOMMENDED VALUES OF B_g AND B_{1s} FOR DIFFERENT
SOURCE FREQUENCIES f

f (Hz)	40	50	60	80	200	400
B_{1s} (T)	1.68	1.56	1.48	1.35	1.00	0.80
B_g (T)	0.8	0.74	0.70	0.64	0.48	0.38

In the induction machines having an outer stator topology, the machine outer surface diameter D_o is given by

$$D_o = D_g + 2(d_{cs} + d_{ss}) \quad (23)$$

where d_{ss} is the depth of stator slot, d_{cs} is the depth of stator core given by

$$d_{cs} = \frac{B_g \alpha_p}{4pK_{fe} B_{cs}} \pi D_g \quad (24)$$

where B_{cs} is the flux density in the stator core, α_p is the ratio of average air gap flux density to peak air gap flux density. The depth of the stator slot d_{ss} is

$$d_{ss} = \frac{2A_s}{K_{ds} J_s K_{cu}} = \frac{2A}{(1 + K_\phi) K_{ds} J_s K_{cu}} \quad (25)$$

where K_{ds} is the trapezoidal slot factor which is used to convert a trapezoidal slot to an equivalent rectangular slot for computational purpose.

Inserting Eqs. (23), (24) and (25) into (13), yields finally an equation for λ_o for the case of an induction machines having an outer stator, radial air gap flux topology

$$\lambda_o = \frac{D_g}{D_o} = \left(1 + \frac{\pi B_g \alpha_p}{2pK_{fe} B_{cs}} + 2K_{ss}\right)^{-1} \quad (26)$$

where $K_{ss} = d_{ss}/D_g$.

Through a computational study, it is now possible to design a series of machines with different power rating, pole pairs and converter frequency, and to examine efficiency for various designs. To assure the reliability of such data, the results obtained from such a study was compared with the published data on NEMA-B series motors, the efficiency of which can be approximately estimated by

$$\eta = 0.7 P_R^{0.03} p^{-0.025} f^{-0.01} \quad (27)$$

Of course, the efficiency of any electrical machine can be obtained by accurately calculating the losses in the machines. However, a detailed calculation of losses would unnecessarily complicate the sizing equation concept which is intended to be a simple, estimate of machine size.

IV. APPLICATION OF THE GENERALIZED SIZING EQUATION TO DSPM MACHINES

The doubly salient permanent magnet (DSPM) machine concept has been presented in Refs. [2] and [9]. For the DSPM topology (Figs. 2 and 3), it can be determined that $K_e = \pi$. Because there is no rotor winding $K_\phi = 0$. Considering the trapezoidal waveforms in Table I (row 8), it can be determined that $K_i K_p = 0.721$. From Eq. (14), the following DSPM machines sizing equation is obtained

$$P_{R(DSPM)} = 0.361 \pi^2 \eta B_g A \frac{f}{p} \lambda_o^2 D_o^2 L_e \quad (28)$$

where the power density of the DSPM machine is

$$\xi_{(DSPM)} = 1.444 \pi \eta B_g A \frac{f}{p} \lambda_o^2 \frac{L_e}{L_t} \quad (29)$$

Due to the structure of DSPM machine, the waveform of the flux in different portions of the stator and rotor have different characteristics. In the stator teeth and the stator inner core, the flux has a unipolar pulsating waveform. In the stator outer core, a nearly constant flux exists. Only in the rotor teeth and core, does their exist an AC flux of the type which exists everywhere in the core of the induction machine.

It is very important to choose reasonable values of the flux density for the different portions of the DSPM machine. A optimization of such values will increase the power density of the machine and decrease the iron loss due to the reduced volume of the core. After an in-depth computational study and optimization, it has been found that the values of flux density in different portions of DSPM machine can be chosen as:

Flux density in stator teeth:

$$B_{1s} = \begin{cases} 5.47 f^{-0.32} & f < 60\text{Hz} \\ 1.48 - (1.48 - 5.47 f^{-0.32})/1.4 & f \geq 60\text{Hz} \end{cases} \quad (30)$$

Depending on the DSPM machine structure, the air gap flux density B_g and rotor tooth flux density B_{1r} normally match B_{1s} .

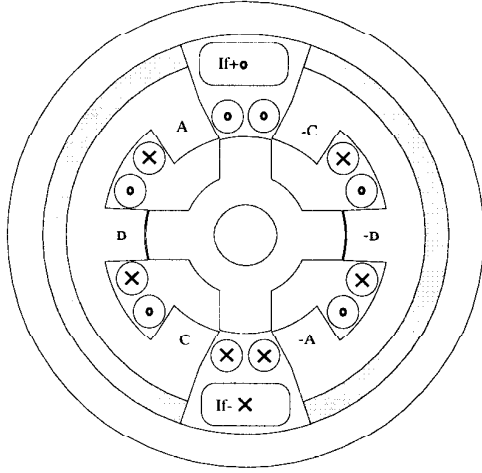

Fig. 2 DSPM4/6 machine with stator pole number $p_s=6$, rotor pole number $p_r=4$, pole pairs $p=4$.

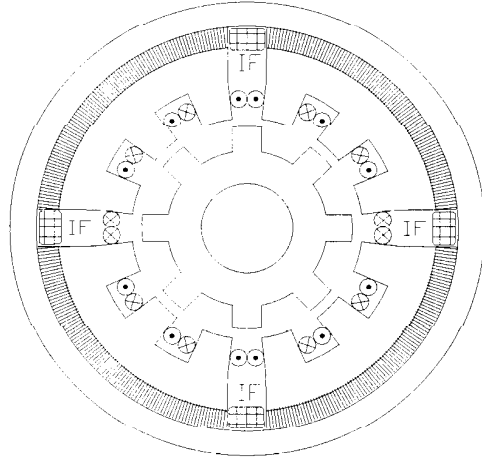

Fig. 3 DSPM8/12 machine with stator pole number $p_s=12$, rotor pole number $p_r=8$, pole pairs $p=8$.

Flux density in stator inner core:

$$B_{cs1}=1.48-(1.48-5.47f^{0.32}) \quad (31)$$

Flux density in stator outer core:

$$B_{cs2}=1.4\sim 1.8 \quad (32)$$

where the value of B_{cs2} is varied by field weakening requirements.

Flux density in rotor core:

$$B_{cr}=4.38 f^{-0.32} \quad (33)$$

In any permanent magnet machine, the air gap flux density B_g can also be expressed, as

$$B_g=K_{focus} B_u \quad (34)$$

where B_u is the attainable flux density on the surface of permanent magnets. The quantity K_{focus} is the flux focusing factor which is related to the structure of the permanent magnet machine. Specifically

$$K_{focus} = \frac{A_{pm}}{A_p} K_d \quad (35)$$

where A_{pm} is the surface area of permanent magnets, A_p is the surface area of working pole per phase and K_d is the flux leakage factor of the PM machines obtained through a finite element study or through design experience.

The optimal values of the aspect ratio coefficient K_L was given considering power density and efficiency, for DSPM4/6 machines $K_L = 1.40\sim 1.55$ and DSPM8/12 machines $K_L=0.65\sim 0.75$.

In the DSPM machines, the outer surface diameter D_o can be expressed as

$$D_o = D_g + 2(d_{cs1} + d_{cs2} + d_{ss} + L_{pm}) \quad (36)$$

where d_{cs1} is the depth of stator inner core given by

$$d_{cs1} = \frac{2\alpha_s B_s \pi D_g}{2 + \alpha_s B_{cs1} p_s} \quad (37)$$

and where α_s is the ratio of stator teeth portion to the stator pole pitch portion. For the structure shown in Figs. 2 and 3, where $\alpha_s = 0.5$, the quantity d_{cs2} is the depth of stator outer core given by

$$d_{cs2} = \frac{\alpha_s B_s \pi D_g}{2 B_{cs2} p_s} \quad (38)$$

The length of the PM is expressed as

$$L_{pm} = \frac{1.2\mu_r B_u}{0.95B_r - \frac{B_u}{K_d}} K_{focus} g \quad (39)$$

where B_r is the residual flux density and depends on PM material, g is the length of air gap. Ref. [8] offers the following equation for estimating the air gap,

$$g = 4.7 \times 10^{-3} p^{-0.5} D_g \quad (40)$$

The depth of stator slot in the case of the DSMP is

$$d_{ss} = \frac{2A}{K_{ds} J_s K_{cu}} \quad (41)$$

Referring to Eq. (13) the inner to outer surface diameter ratio in the case of the DSPM is

$$\begin{aligned} \lambda_o &= \frac{D_g}{D_o} \\ &= \left(1 + 0.8 \frac{B_{fs}}{B_{cs1}} \frac{\pi}{p_s} + 0.5 \frac{B_{fs}}{B_{cs1}} \frac{\pi}{p_s} + \right. \\ &\quad \left. 1.128 \times 10^{-2} \frac{\mu_r B_u}{0.95 B_r - \frac{B_u}{K_d}} K_{focus} D^{-0.5} + 2K_{ss} \right)^{-1} \end{aligned} \quad (42)$$

Using the similar method which was used for the induction machine, the estimated efficiency of the DSPM machine is given by

$$\eta = 0.92 P_R^{0.01} p^{-0.015} f^{-0.01} \quad (41)$$

Again calculating the total losses of the DSPM machines directly will yield a more accurate estimate of efficiency.

V. COMPARISON BETWEEN INDUCTION AND DSPM MACHINES

It is now possible to calculate the power densities of induction machines and DSPM machines through the use of the sizing and power density equations. Fig. 4 shows the comparison of power densities among a 4 pole induction machine (IM-4), a 4-rotor-pole/6-stator-pole DSPM machine (DS4/6) and an 8-rotor-pole/12-stator-pole DSPM machine (DS8/12). Note that a power density improvement of nearly a factor of two can be achieved for high speed machines.

Fig. 5 shows the comparison of efficiencies among the three machines. Assuming that the structure and heat dissipating strategies of these machines are comparable. The same values were chosen for the electrical loading, $A = 60,000 \text{ A/m}$, the current density, $J_s = 6.2 \times 10^6 \text{ A/m}^2$ and the rated output power, $P_R = 75,000 \text{ w}$. The efficiency of the 8/12 pole machine becomes poorer at high speed compared to the 4 pole induction machine since the applied frequency is high for a given speed and thus iron loss becomes a major issue. However, the efficiency of the 4/6 pole machine remains superior to the 4 pole induction machine over the speed range investigated. While corroborating test results are not included in this paper, experimental results for the DSPM machine are contained in a companion paper [10].

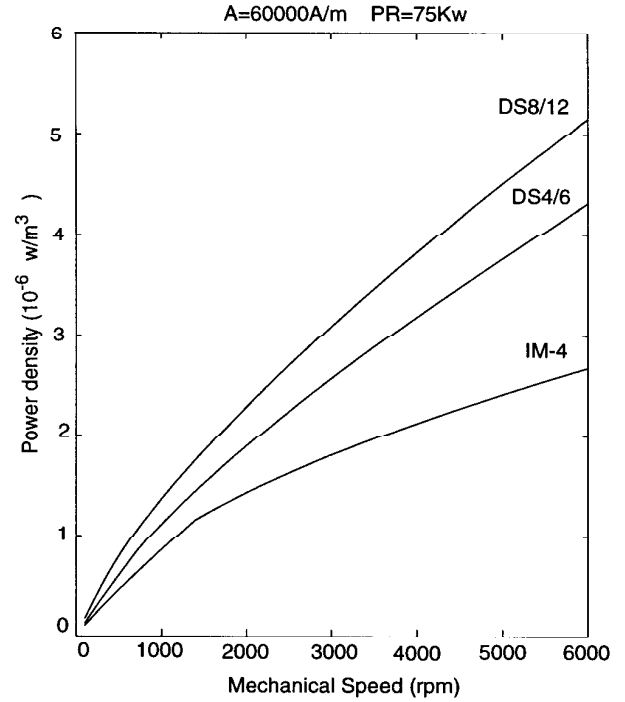

Fig. 4 Power densities of four pole induction machine and DSPM machines.

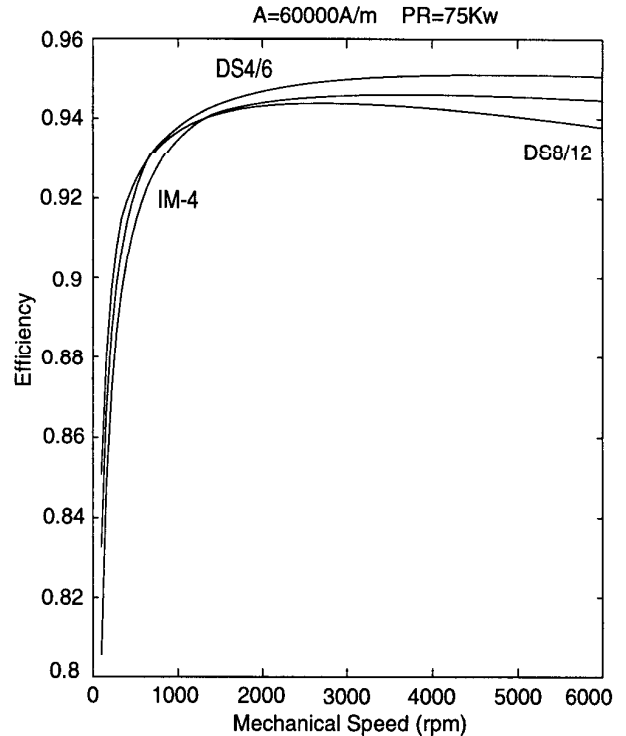

Fig. 5. Efficiencies of four pole induction machines and DSPM machines.

VI. CONCLUSION

In this paper, the following results have been obtained

1. A general purpose sizing and power density equations have been developed for any machine utilizing the main machine dimensions $D_o^2 L_e$, instead of air gap dimension $D_r^2 L_e$. This new approach permits a comparison of the capability of different machine topologies based upon overall occupied volume.

2. Table 1 row 3 presents that the maximum product of $K_i K_p$ is "unity" for the rectangular back emf and current waveforms, which means, for the ideal condition, a machine with a rectangular waveform will generate the maximum power density of any type of electrical machine.

3. Sample applications of the general purpose sizing and power density equations have been developed for both DSPM machines and induction machines.

4. A powerful comparison tool for electrical machines has been presented and common limitations of previous approaches have been eliminated

5. Fig. 4 shows a fair comparison between induction machines and DSPM machines, the DSPM structure is capable of substantially higher power density than the equivalent induction machine.

REFERENCES

- [1] V. B. Honsinger, "Sizing Equations for Electrical Machinery", IEEE Trans. on Energy Conversion, Vol. EC-2, No. 1, March 1987, pp. 116-121
- [2] T. A. Lipo and Yue Li, "CFMs - A New Family of Electrical Machines", JESC'95, Japan, 1995, pp. 1-6.
- [3] T. A. Lipo and F. X. Wang, "Design and Performance of Converter Optimized AC Machines", IEEE Trans. on Industry Applications, vol. IA-20, No. 4 July/August 1984, pp. 834-844.
- [4] W. Schuisky, "Induktionsmaschinen", Springer-Verlag, Vienna, 1957 (in German)
- [5] T. A. Lipo, "Electrical Machine Design", Classroom notes for ECE 713, University of Wisconsin-Madison, 1995.
- [6] S. Huang, J. Luo, F. Leonardi and T. A. Lipo, "A Comparison of Power Density for Axial Flux Machines Based on the General Purpose Sizing Equation." in preparation.
- [7] SiQun Chen, "Electrical Machine Design" (2), Xian Jiaotong University. 1982, (in Chinese).
- [8] E. Levi, "Polyphase Motors -- A Direct Approach to Their Design", John Wiley and Sons, Inc., New York, 1984.
- [9] Y. Li, F. Leonardi and T.A. Lipo, "A Novel Doubly Salient Permanent Magnet Generator Capable of Field Weakening", Conference on Design to Manufacture in Modern Industry (DMMI), Lake Bled, Slovenia, May 29-30, 1995.
- [10] F. Leonardi, T. Matsuo, Y. Li, T.A. Lipo and P. McCleer, "Design Considerations and Test Results for a Doubly Salient PM Motor with Flux Control", IEEE IAS Annual Meeting, Oct. 1996.