



# Research Summary

Yu Hen HU  
Professor

University of Wisconsin - Madison  
Dept. Electrical and Computer Engineering  
1415 Engineering Drive  
Madison, WI 53706  
hu@engr.wisc.edu  
<http://www.ece.wisc.edu/~hu/>



# Overview

- Communication/Signal Processing and Computer Engineering areas
- Face Recognition,
- Wireless Sensor Network Signal and Information Processing,
- Multimedia Signal Processing,
- Design and Implementation of Embedded Multimedia and Communication Systems



# Teaching

- ECE/CS/ME 539 Introduction to Artificial Neural Network and Fussy Systems
- ECE/CS 552 Introduction to Computer Architecture
- ECE/CS 533 Digital Image Processing
- ECE 738 Advanced Digital Image Processing
- ECE734 VLSI Array Structures for Digital Signal Processing
- ECE556 Computer Aided Design
- ECE352 Digital System Fundamentals



# Face Recognition

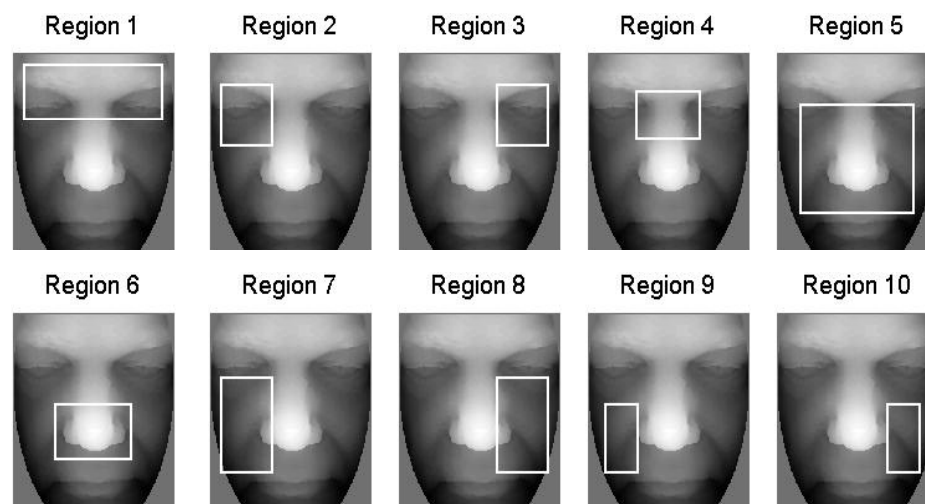
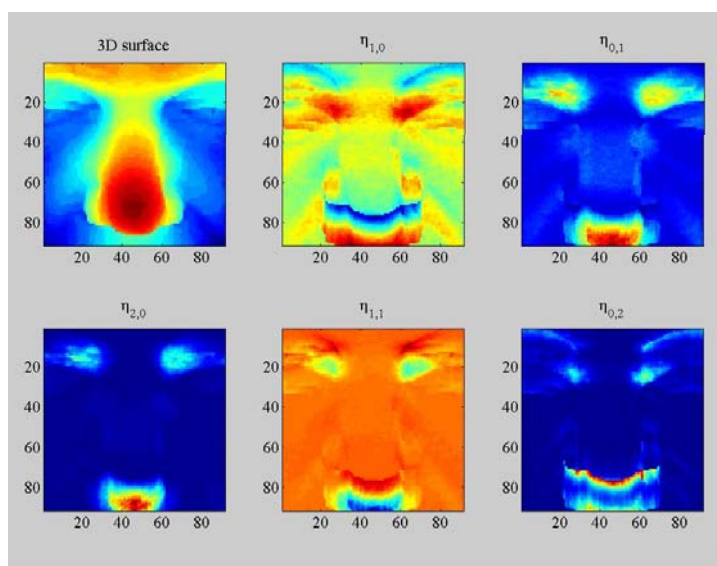

- Collaboration: Profs. N. Boston (ECE/Math), C. Dyer (CS) + 3 PhD students (F08)
- Goal: invariant features for 3D face recognition
- Innovation: novel summation invariants formulation
- Accomplishment: participating FRGC (face recognition grand challenge) achieve 2<sup>nd</sup> best result
- Current focus: camera network. A group meeting on Thursday weekly during fall 2008.



# Wireless Sensor Network Signal and Information Processing

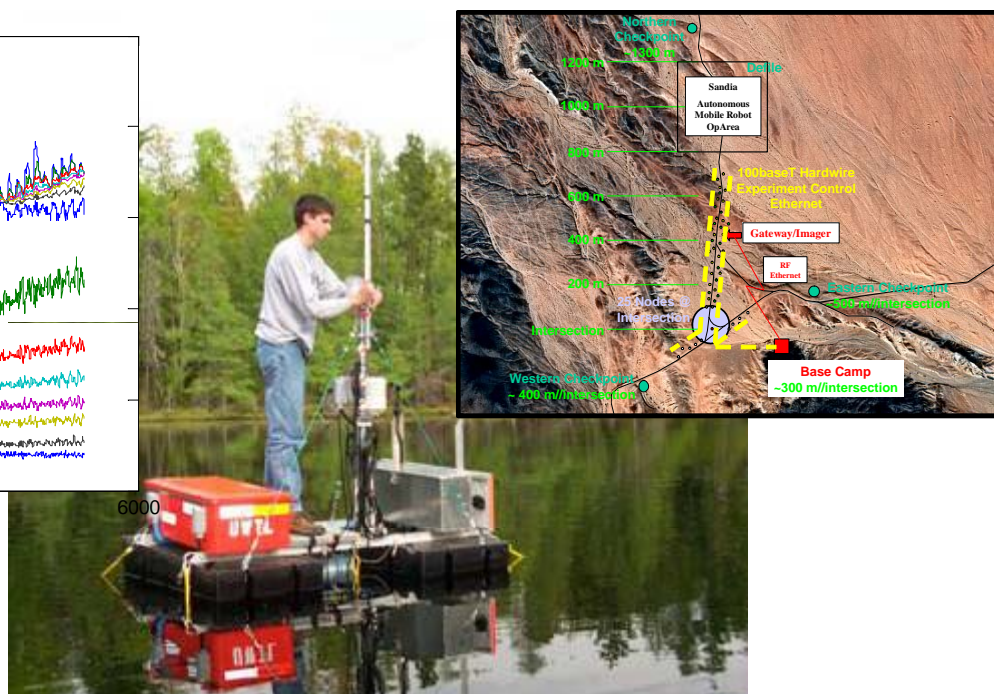
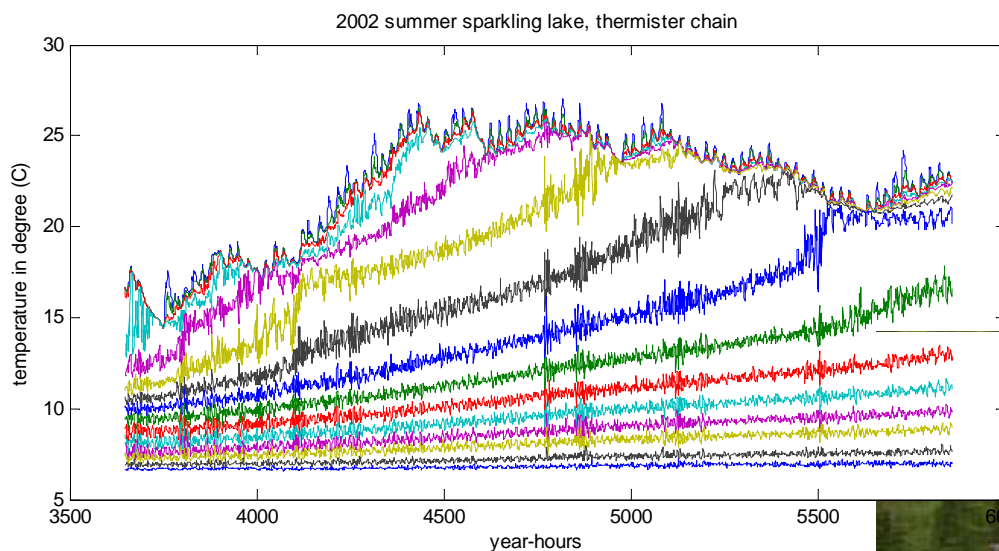

- Collaborators: CLR (UW-Madison), NTUST (Taiwan), NASGS (China), ZJU (China) + 2 PhD students, 2 visitors (F08)
- Topics: Target detection, localization, and tracking; Sensor deployment, sleep scheduling; Sensor data aggregation; Adaptive sensing for environmental monitoring





# Embedded Architecture Design and Implementation Methodology

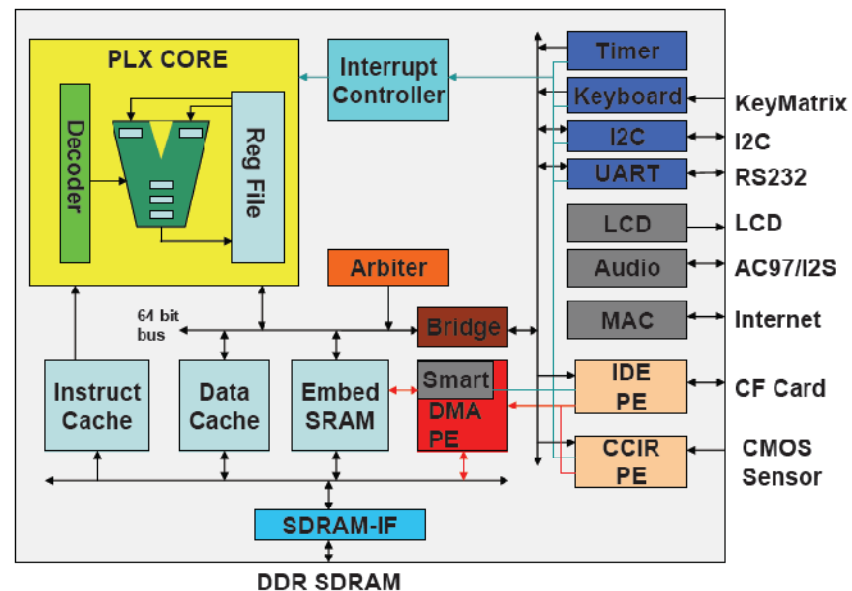
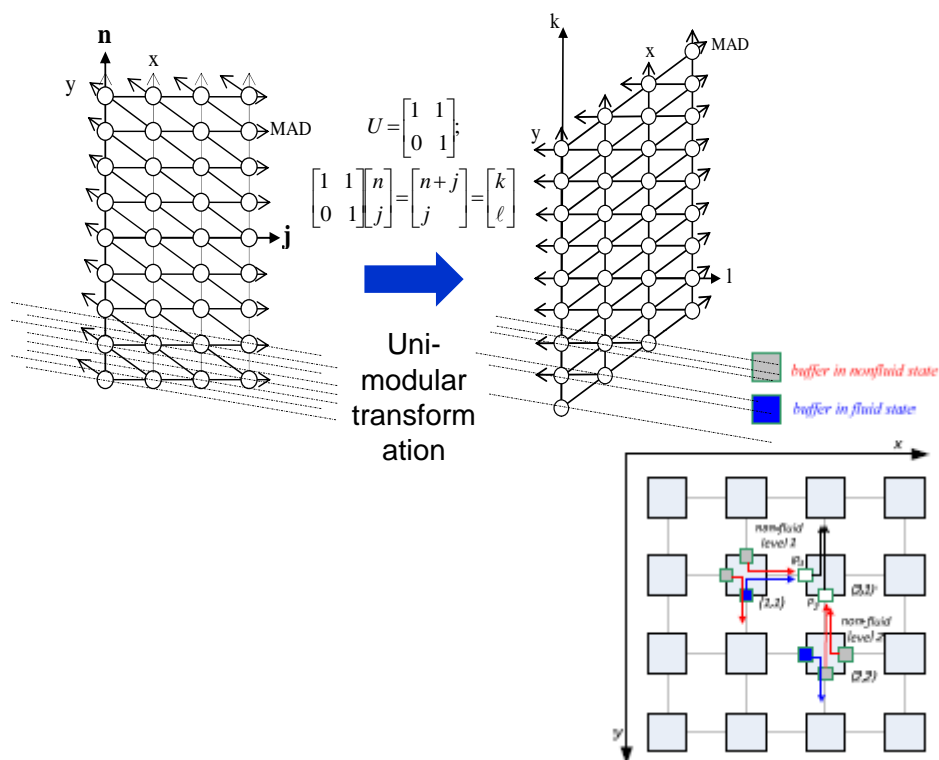

- Collaborators: M. Schulte, NTU (Taiwan) + 2 PhD students, 3 visitors (F08)
- Topics: memory aware sequential scheduling, cognitive and software defined radio architecture, SIMD SoC platform, NoC routing



# VLSI CAD

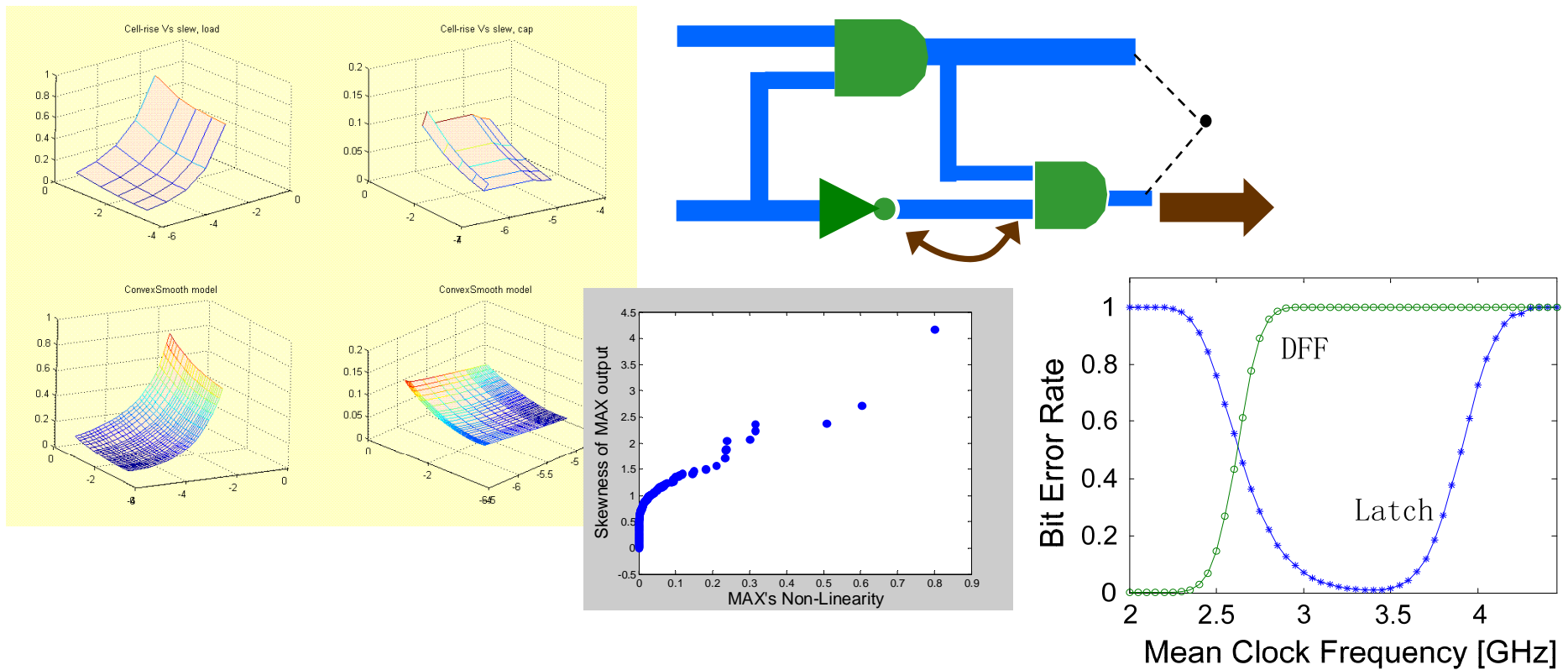

- Topics: transistor sizing with convex optimization, statistical timing analysis,